

Containerlift Operational Information (Maximum Cargo weights are subject to empty shipping container weight).

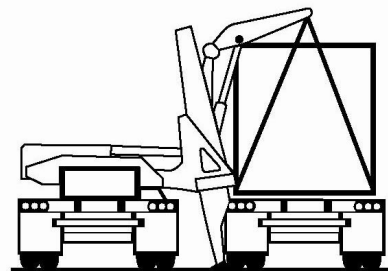
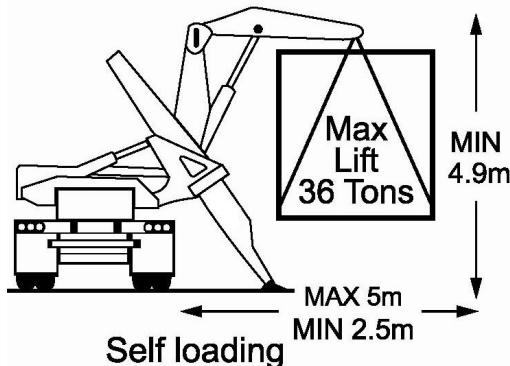
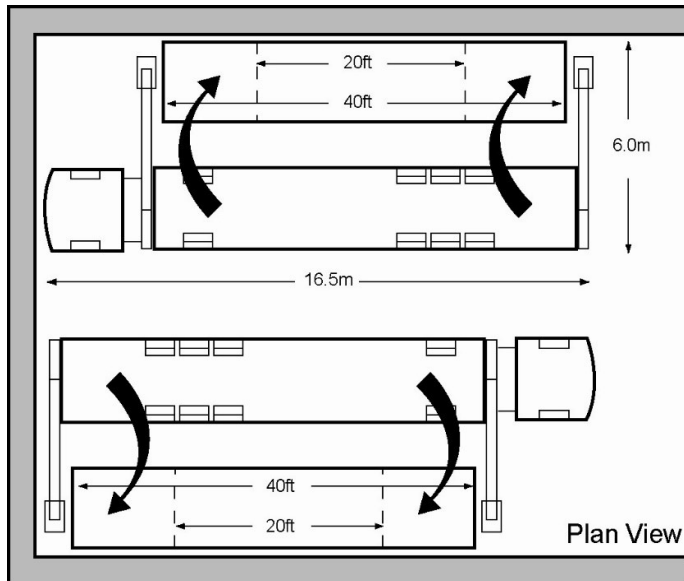
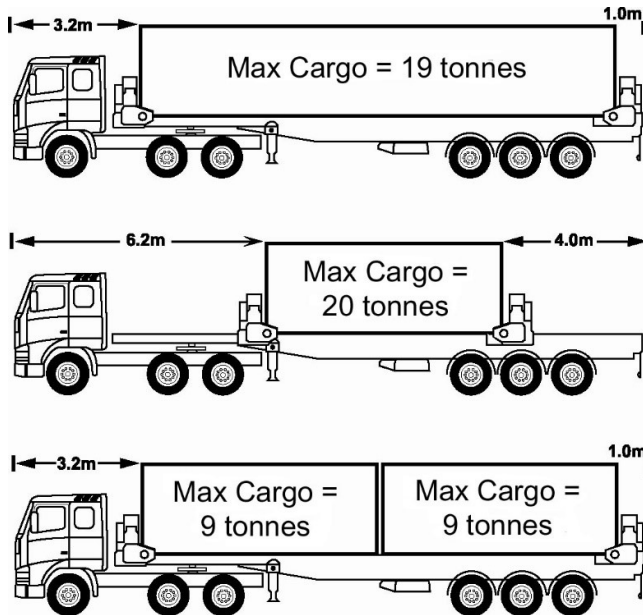

- Ensure the weight advised in your job booking documentation is accurate. Containerlift vehicles are not fitted with weighing systems. Considerable additional charges may be incurred if the weights declared in the booking documentation is inaccurate and a vehicle is found to be overloaded.
- Containerlift vehicles have a crane at each end.
- They lift by attaching chains to the bottom container corners castings.
- Maximum lifting capacity is 36 tonnes.
- Maximum site carrying capacity is 36 tonnes.
- Maximum ground pressure loading is 1.3 MPa.
- **Maximum gross road-carrying capacity is 23 tonnes – this includes the weight of the container** (a 20ft container weighs approximately 2.5 tonnes & a 40ft approximately 4 tonnes).
- Maximum weights shown are for road carried cargo only.
- A vehicle will be provided which is suitable for legally carrying the load weight detailed in the job booking.
- Heavier weights can be carried on the road if the container is lifted onto a standard vehicle. Please discuss details with us before placing your order.
- Containerlift vehicles only lift off to the driver's side.
- Containerlift vehicles are *not* all-terrain – if we get stuck you get charged!
- Containers can only be placed alongside vehicle on the driver's side.
- Containers cannot be lifted on a steep slope.
- Containers cannot be lifted on a steep camber.
- Always allow room (as per diagram).
- If in doubt, please ask – or email us a site plan (with dimensions).
- Remember to specify which end of the vehicle you want the shipping container doors. Unless specified otherwise doors will be delivered to the rear.
- Empty 'storage only' containers can be placed differently using a mobile crane or a vehicle with a single crane.
- A Containerlift vehicle may not be able to reach a container if:
 1. It was delivered by a different type of vehicle or crane.
 2. It has been moved since being delivered.
 3. Site or access conditions have changed.
- If in doubt please ask – so you order the right equipment
- **WE CHARGE FOR FAILED COLLECTIONS OR DELIVERIES.**

1. Definitions

- a) The 'Customer' is the company or individual placing the order and paying our charges.
- b) The 'Site' is the address, including the actual position at the address, where a container is to be deposited or lifted.
- c) An 'Agent' is any intermediary authorised by the 'Customer', who passes instructions or information to us.
- d) The 'Consignee/or' is the individual or company to whom or from whom a container is consigned.
- e) A 'Containerlift Booking Form' is a standard form which must be completed in full and sent to the Containerlift Traffic Office for a job booking to be confirmed.
- f) The 'Job Price', unless agreed otherwise in writing, is:
 - i) Valid for 30 days.
 - ii) Fuel surcharge is applied at rate on date of job.
 - iii) The rate quoted and confirmed in writing.
 - iv) In the absence of confirmation in writing, our standard tariff rate.

2. Vehicle Description

- a) Containerlift lifting vehicles are fitted with purpose built cranes for lifting ISO shipping containers.
- b) They are operated by one man, at ground level, without the need for special facilities or heavy paving.
- c) They can carry and handle 20ft, 40ft, 45ft and 2 x 20ft shipping containers weighing up to 36 tonnes.
- d) 20ft containers being carried as a pair can be delivered individually.
- e) Containers being carried on public roads are restricted to the weights detailed on page 1.

3. Operating Methods

- a) Containers are lifted by cranes mounted at either end of the vehicle which:
 - i) Eliminates the risk of dangerous rotational swing during lifting.
 - ii) Ensures position of container is stable and under control at all times during lifting.
 - iii) Ensures accurate placement of container without man-handling.
- b) Cranes are connected by chains to bottom corner castings of container which:
 - i) Ensures that operator remains on ground level at all times.
 - ii) Eliminates the risks associated with operators climbing on top of containers.
- c) Operator controls all crane movement from a safe distance by remote control.
- d) Containers can be self loaded/unloaded, lifted to/from other road vehicles and rail wagons.
- e) Containers can only be lifted on firm level ground with max slope or camber of 5%.
- f) Only containers fitted with standard, accessible ISO bottom corner castings can be lifted.
- g) Corner castings must be in conventional positions for ISO shipping containers.
- h) Containers with protrusions to the front or rear of the container cannot be handled.
- i) Each lift takes approximately 5 mins (from positioning of vehicle).
- j) Alternative lifting means can be supplied where Site circumstances prevent the use of a Containerlift vehicle.
- k) Failed deliveries or collections will be charged for - if in doubt please consult us before placing order.
- l) Containerlift Operations are conducted in accordance with the following, full copies of which are available on request:
 - i) RHA Conditions of Carriage & Storage.
 - ii) BIFA Conditions of Trade for customs clearance and Freight Forwarding. All export shipments are carried out under CFR INCO terms unless otherwise stated in writing.
 - iv) CPA Contract Lift Conditions.
 - v) BS7121 'The Safe Use of Cranes'.
 - vi) LOLER 'Lifting Operations and Lifting Equipment Regulations'.

If there is a variance between Containerlift's terms and condition and the terms and conditions laid out in i) to v) above, Containerlift's terms and conditions will preside.

4. Service Options

- a) At Collection: Collect or Lift On
- b) At Delivery: Deliver or Lift Off
- c) On Site: Leave, Wait & Load, Wait & Unload, Swapover

5. Operating Limits

See Drawings on Page 1

6. Site Access

- a) Containerlift vehicles are 16.5m long articulated vehicles.
- b) They need an accessible space 16.5m x 6m to lift a container off.
- c) Containers are lifted on and off to the driver's side and parallel to the vehicle only.
- d) Unless specified otherwise, containers are always delivered with doors to rear of vehicle.
- e) Ensuring there is adequate site access is the sole responsibility of the Customer.
- f) Any advice given by Containerlift, whether written or verbal, is intended for guidance only (on site drawings).

7. Health & Safety

- a) All Operators are fully trained in the use of lifting equipment and safety procedures.
- b) A copy of our Operating Method Statement, Risk Assessment and Safety Measures (2001) appears on Page 5.
- c) It is the Customer's responsibility to ensure those at Site are made aware of Containerlift Health & Safety and other statutory requirements.
- d) In accordance with CPA Contract Lift Conditions, the Containerlift Operator is in sole charge of lifting operations at Site.
- e) The Containerlift Operator's decision will be final.

8. Insurance

- a) Insurance cover will be provided as follows (solely for circumstances where Containerlift acts negligently):
 - i) Loss or damage to Containerlift plant or other property.
 - ii) A Maximum Liability of £10,000 in respect of the value of goods lifted. (Additional goods lifted cover available at £5.00 per £1,000).
 - iii) A Maximum liability of £2,000,000 in respect of loss or damage to other property and injury to other persons.
 - iv) A Maximum liability of £5,000,000 in the event of death.
- b) Under RHA Conditions of Carriage Containerlift will provide cover for a Maximum Liability of £1,300 per ton for goods whilst in transit between Sites. If additional cover is required please ask for a quotation.
- c) Insurance cover for all other risks, including risks in excess of the above limits, must be provided by the Customer or we can provide a quote.

9. Quotations

All quotations, whether they include container transportation or not, include up to one hour at each Site visited

10. Additional Charges

- a) Site Charges, if not pre-booked (lifting vehicles) = 1st hour free, then 2nd hour onward £100 per hour or part thereof waiting.
- b) Site Charges, if not pre-booked (non-lifting vehicles) = 1st 3 hours free, 4th hour onward £100 per hour or part thereof waiting.
- c) Re-direction for lifting vehicles - £150 plus £3.00 per extra mile to re-direct to an alternative Site from a designated Site.
- d) Re-direction for non-lifting vehicles - £100 plus £2.00 per extra mile to re-direction to an alternative Site from a designated Site.
- e) Lifting vehicles - CPA Terms & Conditions Indemnity, Hired in Plant Insurance charges - £50 per lift
- f) All times quoted are per hour or part thereof.
- h) Hazardous loads (requiring an ADR qualified Driver) will be subject to a 20% surcharge.
- i) Class 1 Hazardous (explosives), Class 7 Hazardous (radioactive) and Section 5 goods (fire-arms and ammunition) are subject to special quotation.
- j) Consignees/ors will be required to sign a delivery/collection note, either paper and/or electronic, giving Site arrival and departure times upon which charges will be based.
- k) Disputed times will be verified by satellite positioning records. Such verification will be accepted as final unless otherwise agreed in writing.
- l) Emailed confirmation of additional charges will be sent to the Customer by Containerlift within two working days of completion.
- m) Containerlift will notify the Customer by telephone and/or email giving confirmation of delays for any of the reasons in item n).
- n) Delays caused through any of the following reasons will be charged at the above hourly rates and will attract an additional administrative charge of £30.00:
 - i) Delays caused through non-release of containers by docks or depots.
 - ii) Delays caused through non acceptance of containers by docks or depots.
 - iii) Delays caused through inaccurate, incomplete or late instructions.
 - iv) Delays caused through late alteration to instructions.
 - v) Delays caused through inadequate pre-advice regarding site access.
 - vi) Delays caused through inadequate pre-advice regarding site conditions.
 - vii) Delays caused through inadequate pre-advice regarding container positioning.
- o) If containers cannot be delivered to Site in the location requested and the Customer does not provide a suitable alternative location before the end of the business day. Containerlift will deliver the containers to a storage facility and storage charges will be incurred at a minimum rate of £25 per 24 hours or part thereof per TEU and LOLO charges. All storage charges must be paid in advance before a re-delivery commences.
- p) If a vehicle and driver is kept out overnight on a job that has overrun longer than was originally booked, an overnight surcharge will be incurred of £275.
- q) If a vehicle is believed to be overloaded we will divert the vehicle directly to the nearest public weighbridge. If the vehicle is found to be within the legal load limit it will continue with the job and no additional charges will be raised. If, after weighing, the vehicle is found to be overloaded and contrary to the weight advised in the job booking documentation considerable charges will be incurred including but not limited to the vehicle waiting time, diversion charges, weighbridge costs, administration charges and costs associated with other vehicles that may need to be deployed.

11. Reservations

- a) Containerlift reserve the right, without prior notice or reduction in price, to suspend completion of a job where:
 - i) Excessive delays, through causes listed above, prejudice other work booked for the vehicle concern.
 - ii) The Containerlift Operator judges Site conditions to be unsafe.
 - iii) The Containerlift Operator judges that lifting could be more safely completed by alternative means.
- b) Containerlift reserve the right to make additional charges where:
 - i) Additional costs are incurred through any of the causes listed above.
 - ii) Additional costs are incurred through delays caused by any of the causes listed above.
 - iii) Additional costs are sustained by Containerlift as a result of inaccurate information about a container or its contents leading to fines, prosecutions and loss of revenue.
- c) Containerlift reserve the right to deliver a container to an alternative Site and make a charge for so doing where the Customer cannot be contacted and/or is unable to issue acceptable alternative instructions if:
 - i) The delivery Site designated by the Customer refuse to accept the container for any reason.
 - ii) The delivery Site designated by the Customer cannot be found.
 - iii) The delivery Site designated by the Customer is inaccessible.

12. Disclaimers

- a) Containerlift, except where it is proven negligent, will not accept liability for costs and will be indemnified by the Customer against liability for any costs arising where:
 - i) Consequential losses and/or liquidated damages of any sort are sustained.
 - ii) A Containerlift vehicle arrives late for any reason.
 - iii) Damage occurs on Site for any reason.
 - iv) Incorrect instructions are issued by a source which Containerlift might reasonably conclude to be the Customer, the Agent or the Consignee/or
 - v) Container Detention charges are levied (unless details of liability notified in writing before commencement of job).
 - vi) Loss/Theft occurs of documents accompanying the container and carried by the driver.
 - vii) Damage to third party vehicles or rail wagons is sustained resulting from lifting on or lifting off containers.
 - viii) Costs are incurred by Customers or other parties resulting from incorrect or incomplete information being supplied to Containerlift.
 - ix) A container is used for any illegal purpose.
- b) Containerlift will not accept costs incurred resulting from acceptance by Containerlift drivers of containers that are not fit for their purpose in any way unless:
 - i) The container has obvious and serious damage to the sides or ends that can be clearly seen from outside the container.
 - ii) The container is not the type or size ordered on the instructions to Containerlift.
 - iii) Containerlift have agreed in writing to make a special inspection and have failed to do so.
- c) Damage or other costs have arisen through the Containerlift driver, without written authorisation, assisting or advising on packing or unpacking of goods.
- d) Claims arising from damage/obstruction caused by Containerlift acting on instructions from the Customer, Agent or the Consignee/or.
- e) Recovery of a Containerlift vehicle from a Site is required for any reason other than the breakdown of the vehicle.
- f) Costs are incurred by Containerlift, of any nature whatsoever, arising from mis-declaration or omission of information from the Customer or Agent.
- g) Damage to containers or contents under any circumstances which is not reported within 48hrs of discovery.

13. Refunds & Cancellations

- Jobs that are cancelled for any reason will be charged/refunded as follows:
- i) If a confirmed job is cancelled more than two full working days before the job is due to commence, including the commencement of any ancillary work in preparation for the job, a full refund will be given.
 - ii) If a confirmed job is cancelled less than two full working days before the job is due to commence, including the commencement of any ancillary work in preparation for the job, the job will be charged at the full job price. No refund will be given.

14. Delivery and Collection Times

- a) Bookings will only be taken for an AM or a PM collection or delivery.

Containerlift Services Ltd
Gallop House, Haslers Lane, Great Dunmow
Essex CM6 1XS
ENGLAND

Tel: +44 (0)1371 879400
Email: enquiries@containerlift.com
Website: www.containerlift.com

*Containerlift Carriage, Lifting & Shipping -
Terms & Conditions of Trade V1.5
Last Updated 1st September 2021*

- b) A specified delivered time can be requested in writing and in accordance with Containerlift's Premium Delivery service.
- c) However, with a limited fleet of specialised lifting vehicles, it is impossible to make assertions or guarantees that Preferred times will be met.
- d) Factors beyond our control such as Port delays, weather, Container Depot delays, breakdowns and traffic also make the guarantee of arrival times impossible.

15. Terms & Conditions of Payment

- a) Unless a credit account is held all Bookings must be paid for before a job is commenced.
- b) Customers without credit accounts can pay by credit card, BACS or Banker's Draft provided cleared funds have been received before commencement of job.
- c) Credit Accounts may be suspended or cancelled if the agreed limits are exceeded.
- d) Credit Account Customers will be required to make payment 30 days from invoice date unless specifically agreed otherwise in writing.
- e) Invoice or additional charge queries must be made in writing no more than 14 days from invoice date.
- f) Under the Late Payment of Commercial Debts Regulations 2013 Containerlift is entitled to claim late payment interest at 8% above the Bank of England base rate, £40 per invoice and compensation and recovery costs.
- g) Set-Off or 'Contra' payments will only be accepted if agreed in writing.

16. Confidentiality

As required by the General Data Protection Regulation 2018 we advise you that your information may be passed to our bankers/financiers for the purposes of:

- i) Making credit reference agency searches.
- ii) Obtaining credit insurance.
- iii) Credit control.
- iv) Assessment and analysis including credit scoring, market, product and statistical analysis.
- v) Securitisation & Protecting our interest

We will provide you with details of our bankers/financiers and that of any credit reference agencies used on request. Copies of our Data Policies are available upon request.

17. Acceptance

Bookings will not be considered confirmed unless:

- i) Written confirmation is received on a standard Containerlift Booking Form (unless agreed otherwise in writing).
- ii) All relevant information and instructions have been completed.
- iii) The Booking Form has been received by Containerlift by email or any other method which has been agreed in writing.
- iv) Terms of payment have been agreed by Containerlift.
- v) Unless otherwise agreed in writing all quotations and jobs will be based on the use of Containerlift self loading semi-trailers (Sidelifters, Swinglifts or SLTs).

18. Information Required

- a) For Invoice:
 - i) Full Name, Address, Telephone & Email address, contact name and order or job number/reference of Customer.
 - ii) Any other information required by the Customer without which passing and payment of invoice might be delayed.
- b) For Collection:
 - i) Full Name, Address, Telephone Number, and Contact Name at Collection Site.
 - ii) Full Name, Contact Name & Telephone Number of Shipping Line or container owner/operator.
 - iii) Valid instructions regarding collection procedures, documentation and/or release references required.
- c) For Delivery:
 - i) Full Name, Address, Contact Name and Telephone Number at Delivery Point.
 - ii) For EXPORTS - Name & Telephone Number of Shipping Line's port office of agent, shipping line booking reference, name of vessel, closing date, and Destination Port.
- d) For Container
 - i) Container Number (if known), size (20ft, 40ft, 45ft, 2 x 20ft or 13.6m swapbody), type (eg high cube, flat rack etc), empty or full, nature of cargo and hazard class (if any), gross weight (including container) and position of doors (front of rear of trailer)
- e) Any other information or instructions essential to the satisfactory completion of the Job.

Containerlift Sidelifter Method Statement

Containerlift vehicles are articulated combination vehicles comprising a tractor unit and semi-trailer with overall length of 16.5 m. The semi-trailer is designed and purpose built to lift and carry shipping containers weighing up to 36 tonnes gross weight.

To lift a container onto the vehicle the following procedures are followed:
Vehicle pulls alongside the container parallel to its length.
Hydraulic stabilizer legs are deployed at either end of the container.
Hydraulic lifting arms are deployed at either end of the container.
Lifting chains are used to connect the lifting arms to the bottom corner casting of the container.
Container is lifted from the ground and over the side of the semi-trailer.
Container is lowered onto locating pins/securing locks on the bed of the semi-trailer
Hydraulic stabilizer arms and legs are withdrawn.
Vehicle drives away.
To lift a container off the vehicle the same procedures are applied in reverse order.

Containerlift Sidelifter Risk Assessment

Overturning Due to Incorrect Operation

- Risk – Nearside overturn due to max SWL container being moved at full speed and maximum height from off-side to limit of near-side travel.
- Control – Operator training forbids the movement of containers across the vehicle deck at more than 6 inches above twist lock height. Movement within this height is restricted by near-side mounted check plates.
- Risk – Offside overturn only possible if stabilizer legs not deployed.
- Control – Leg mounted micro switches only permit crane operation when legs deployed.

Incorrect Sitting

- Risk – Double stacking max SWL containers on nearside-down camber.
- Control – Operator training only permits loaded box double stacking/de-stacking on level ground.

Instability of base

- Risk – Stabilizer leg sinking into soft ground or through thin top surface into soft ground. Risk limited to descent of container from maximum lift height of 8ft 6in vertically to ground.
- Control – Operator instructions are that lifting only to take place on suitable ground (as above) and otherwise only with written undertaking from customer or by use of timber bolsters.

Load weight exceeding SWL

- No risk – crane hydraulic pressures are set to prevent lifting of container above SWL from vehicle. Lifting of container above 30% over SWL from ground can only be unstable if centre line of container beyond point of stabilizer leg contact with ground. Risk is limited to vehicle counterbalancing lift. (i.e. progressive application of lift mechanism will progressively lift vehicle from the ground).

Load falling from crane

- No risk – Container is fixed at the four bottom corner castings and can only become detached due to structural failure of the crane or the container.

Personnel struck by crane or lifted objects

- No risk (unless through structural failure). Container is secured and lifted independently at both ends eliminating load swing associated with single point lift cranes. Movement of container during lift is under total operator control at all times and all hydraulic cylinders are fitted with safety valves preventing movement in the event of pressure failure. Operator's hardhat is to prevent injury through careless movement of head (not equipment).

Containerlift Safety Measures

1. Containerlift Normal Procedure: Flashing beacons at the front and the rear of the vehicle are operated. In areas where there is a likelihood of pedestrian and vehicular traffic the operator will ensure that the lifting area is clear before operating. Traffic Cones and/or chain link fencing suspended between traffic cones are available on request.
2. The lifting machinery is a Steelbro or Hammar Sidelifter which is a specialized vehicle designed specifically for lifting and carrying ISO shipping containers with a safe working load of 36 tonnes. No accessories are used and the equipment is inspected and tested in accordance with LOLER. Additionally the equipment, which is designed to operate at 30% above safe working load, is regularly tested to 25% above safe working load. Safe working load is marked on the machinery.
3. Slingers are not used as the lifting procedure is a one man operation. There is no provision by the C.I.T.B. for certification of Containerlift operators as the equipment is primarily used in the shipping industry. Operators are fully trained, assessed and certified as competent in accordance with manufacturer's recommended procedures. The operator will be able to produce his certificate of Competence on Site.
4. Containerlift equipment is designed exclusively for the lifting of ISO containers that are, subject to structural survey, inherently stable and secure. Stability and security of the contents of containers lifted and transported by Containerlift vehicles are outside the control or responsibility of the Containerlift operator.
5. Containerlift operators are issued with hard hats and high visibility jackets.
6. Containerlift vehicles are fitted with their own stabilizers and do not carry additional equipment. The ground contact feet are designed to spread the load sufficiently to allow max SWL to be handled on any surface which is suitably constructed for a 44 ton gross vehicle to drive on. If the lifting surface requires additional bolstering this can be arranged on request (subject to prior consultation)
7. Containerlift vehicles do not require rigging or de-rigging. The Containerlift Operator supervises lifting operations on site and attaches lifting devices to the bottom corner castings of the ISO container.